



#### WARNING – MOUNTING SAFETY

- Before mounting the soundbar, carefully inspect the chosen installation area to ensure it is completely free of any hydraulic lines, fuel lines, brake lines, electrical wiring, or other critical components.
- Mounting hardware must not interfere with or damage any of the motorcycle's systems. Drilling or securing the soundbar in inappropriate locations may cause serious safety hazards, including fuel leaks, brake failure, electrical shorts, or system malfunctions.
- DO NOT mount near or through any fluid-carrying lines or cables.
- DO NOT install in locations where the soundbar or wiring may affect steering, braking, throttle operation, or rider visibility.
- ALWAYS check both sides of any panel before drilling.
- CONSULT a qualified technician if you are unsure about your mounting location.
- Improper installation may result in serious injury or vehicle damage. Follow all mounting instructions carefully and use only the recommended tools and hardware.

This equipment has been tested and found to comply with the limits for a Class B digital device, pursuant to part 15 of the FCC Rules. These limits are designed to provide reasonable protection against harmful interference in a residential installation. This equipment generates, uses and can radiate radio frequency energy and, if not installed and used in accordance with the instructions, may cause harmful interference to radio communications. However, there is no guarantee that interference will not occur in a particular installation. If this equipment does cause harmful interference to radio or television reception, which can be determined by turning the equipment off and on, the user is encouraged to try to correct the interference by one or more of the following measures: Reorient or relocate the receiving antenna. Increase the separation between the equipment and the receiver. Connect the equipment into an outlet or a circuit different from that to which the receiver is connected.

Consult the dealer or an experienced radio/TV technician for help.

Warning: Changes or modifications to this unit not expressly approved by the part responsible for compliance could void the user's authority to operate the equipment.

FCC Radiation Exposure Statement - This equipment complied with FCC radiation exposure limits set forth for an uncontrolled environment. This equipment should be installed and operated with minimum distance 20cm between the radiator & your body.



[WWW.DTCAUDIO.COM](http://WWW.DTCAUDIO.COM)



[SUPPORT@DTCAUDIO.COM](mailto:SUPPORT@DTCAUDIO.COM)

# DTC AUDIO

DTC Audio is a direct-to-consumer brand built by a team of industry veterans who have worked behind the scenes for some of the biggest USA names in audio. With decades of combined experience designing and developing top-tier products, the DTC Audio team brings that same expertise directly to you—without the middleman. That means you get high-quality, premium sound crafted by experts, all at a price that reflects true value. By cutting out the retail markup, DTC Audio delivers the best of both worlds: exceptional performance and accessible pricing. This product is designed and developed in the USA!

## PRODUCT MANUAL & INSTALL GUIDE

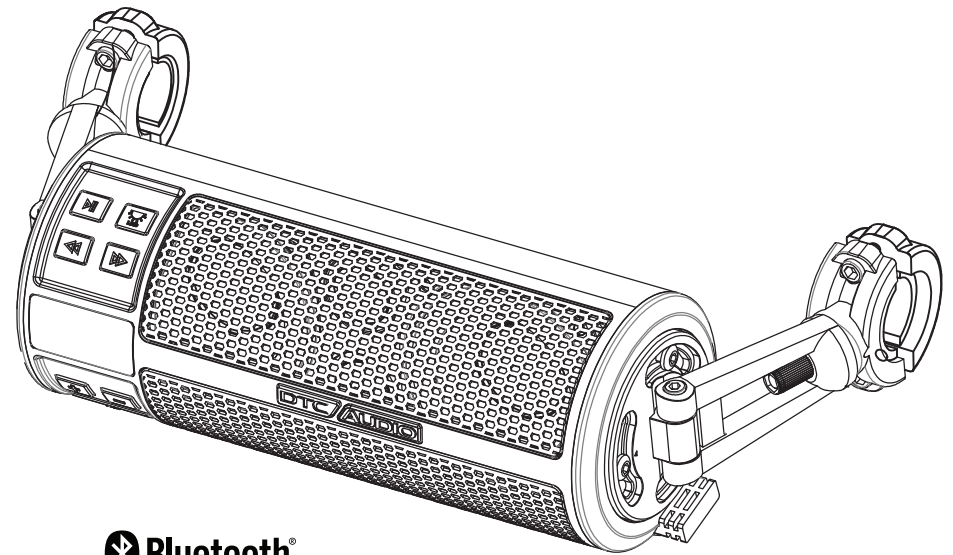

 Bluetooth®

# PSB4



## PSB4

### READ THIS FIRST

The PSB4 soundbar is built for versatility and adventure, offering multiple mounting options that make it easy to install on your ATV, boat, Ryker, golf cart, or motorcycle. Designed to thrive in any outdoor environment, it features rugged weather-resistant construction, vibrant RGB lighting, and an easy-to-read LCD screen. Equipped with four high-performance speakers, it delivers powerful bass and crystal-clear vocals—even at highway speeds. With multiple source inputs including USB charging, the PSB4 keeps your music going wherever you ride. Plus, its low power draw ensures it won't drain your battery during off-season storage, so it's always ready when you are.

### FEATURES

- 2 × 3" mid-bass woofers
- 2 × 1" Teton dome tweeters
- IP67 rated
- Sources: FM, Bluetooth, Aux input, and USB with charging
- 3.5mm line output to augment your audio system with subwoofers or additional speakers
- RGB lighting
- Backlit LCD display
- Low standby current to protect your battery when vehicle ignition is off! No need to worry in the off season, this soundbar will not kill your battery.

### SPECIFICATIONS

Operational voltage	8-24VDC
Power	100W
Frequency response	50Hz-20kHz
Handlebar clamps	.75-1.25" diameter
Soundbar dimensions	9" x 3.25" diameter

### CONTROLS

#### Power button

- Short press to turn on.
- Short press when on to change sources.
- Long press to turn off.

#### Volume up/down

- Press either button to adjust the volume for any source.

#### Forward/Back buttons

- Press to skip tracks forward or backward in Bluetooth or USB mode.

#### Play/pause

- Press to play or pause in Bluetooth or USB mode.
- Press to mute when listening to FM radio.

#### LED button

- Press the button 9 times to cycle through the pre-programmed color selections.
- Press a 10th time to turn the LEDs off.

#### To connect to bluetooth:

- Set the source to Bluetooth; the Bluetooth symbol will begin flashing.
- Open the Bluetooth settings on your device, search for PSB4, and click Connect.
- Once connected, the Bluetooth symbol will stop flashing.

#### USB mode

- Set the source to USB, and the PSB4 will automatically start playing songs.
- Approved formats: WMA, MP3, WAV, and FLAC.

## MOUNTING

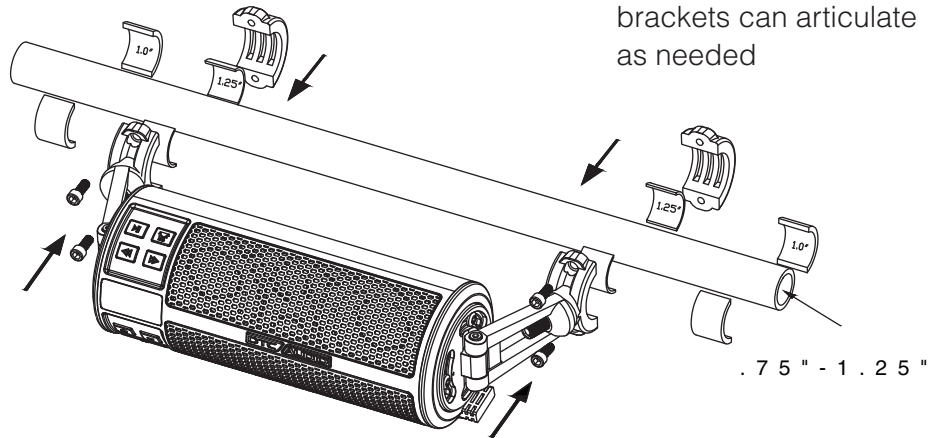
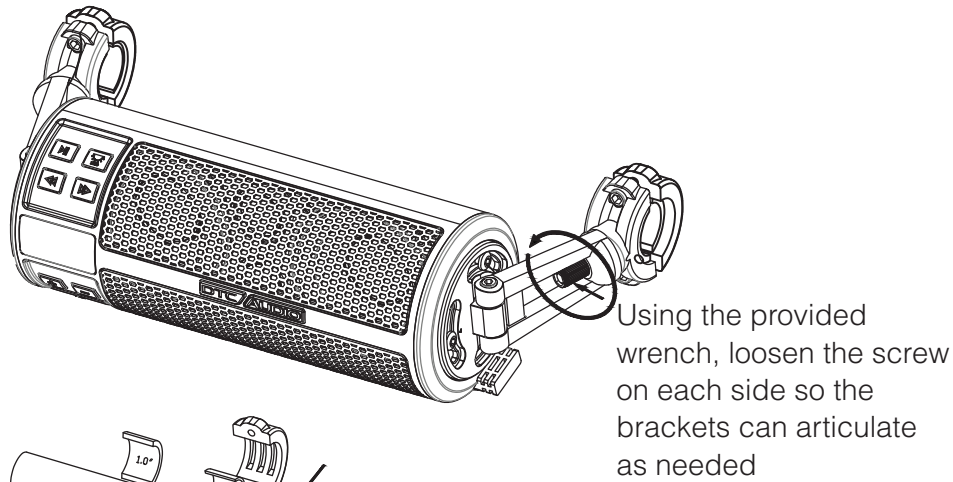

Loosen the two screws on each clamp and attach the mounting bar. If your mounting diameter is between 1" and 1.25", use the provided rubber inserts.

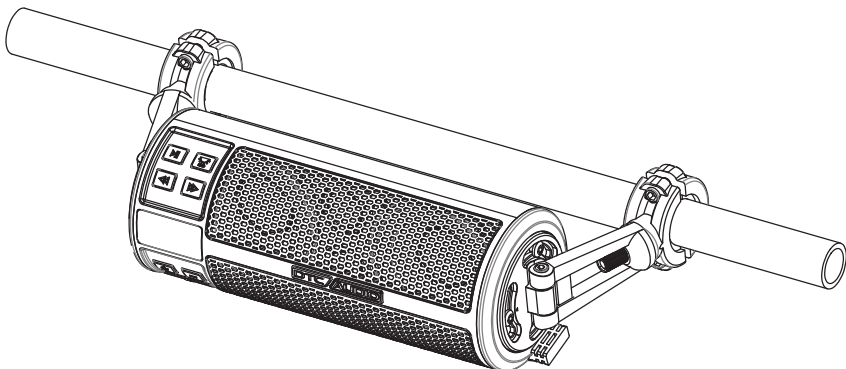

## INSTALL INSTRUCTIONS

### Wiring:

Yellow – 12V+ constant, should be connected directly to the vehicle positive battery terminal

Black – 12V negative, should be connected directly to the negative battery terminal

Blue – 12V switched, This should be connected to the vehicle ignition or external switch. When this wire is connected to +12V the soundbar will turn on.

Line output: The black female 3.5mm jack is a 2.5v low level audio out designed to drive external amplifiers. This allows the PSB4 to be used as the main source while adding more audio components to your system.

## TROUBLESHOOTING

### No output:

Confirm all wiring is firmly connected. Both +12V must have +12 Volts present and GND must be connected to chassis' ground or to the negative battery terminal.

Confirm the signal source is connected via Bluetooth or the auxiliary cable is connected to both the source and the MXASB9

### Weak output:

Check Bluetooth device volume.

### Unwanted noise:

Whine that increases and decreases with engine speed - confirm the Amp & Source unit are grounded properly.

Clicking or popping noise at a rate that follows engine speed - this is often induced by the vehicles ignition system.

Confirm that the vehicle is equipped with resistor spark plugs and wires. The ignition system may need service.